

# TOM-2 Total Oxidizer Monitor w/Mitigation

## Operators Manual

For Model TOM-2095M, Part Number 01-210-1

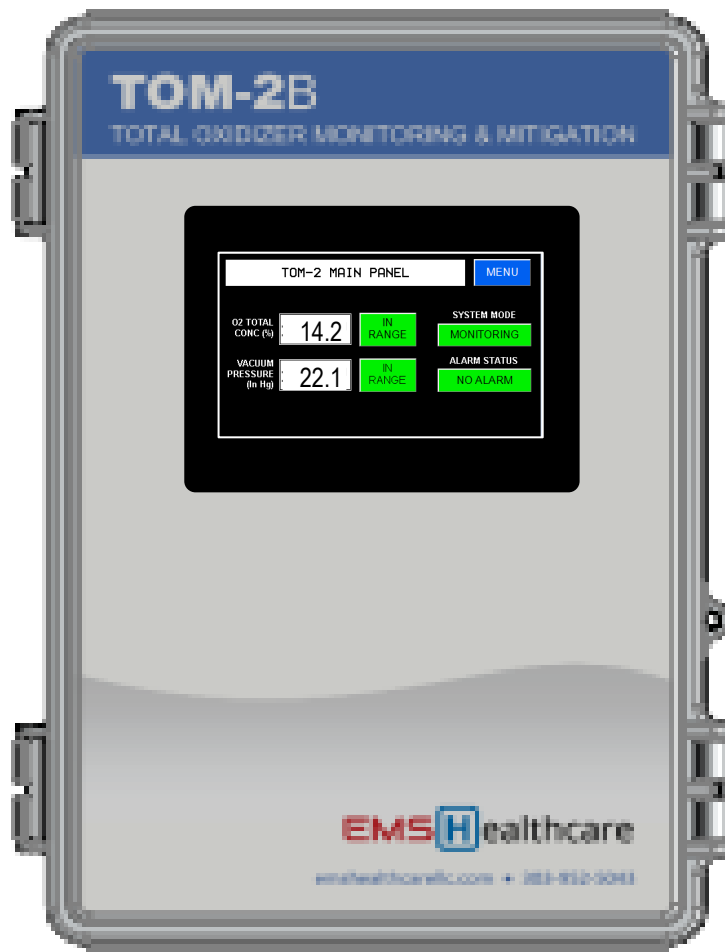

# TOM-2 Operators Manual

## Table of Contents

System Overview .....	3
Model Features .....	3
System Specifications .....	4
System Equipment .....	5
System Installation .....	6
TOM-2 Unit Installation .....	6
TOM-2 Transmitter and Valve Installation .....	7
Facility Interface Wiring.....	8
Mitigating Gas .....	9
Initial Power Application.....	9
System Operation .....	11
System Configuration .....	11
Settings .....	12
Transmitter Calibration .....	15
Test Mode .....	16
Statistics.....	17
Faults .....	18
Logging In.....	19
Adjusting Date and Time.....	19
Data Logging .....	19
System Maintenance.....	20
Annual Compliance Reporting.....	20
Periodic Transmitter Check .....	20
O2 Concentration at Vacuum Pressure .....	21
Schematic Diagram .....	22
Limited Warranty.....	23

# TOM-2 Operators Manual

## System Overview

With the introduction of NFPA 99 2012 edition came an entirely new requirement for medical-surgical vacuum systems that are also used for Waste Anesthetic Gas Disposal (WAGD). For these combined-use systems, the NFPA now requires the total concentration of oxidizers (oxygen and nitrous oxide) be maintained below 23.6 percent or the materials, lubricants, and sealants within the vacuum pump be inert to these oxidizers for new installations (reference section 5.1.3.8.1.2. (2)). The NFPA 99 2018 edition imposes this requirement on all (existing and new) combined-use vacuum systems and the 2021 edition removes nitrous oxide from the requirement.

The **TOM-2** Total Oxidizer Monitor (US patent #11,806,473 B2) from EMS Healthcare, LLC is a gas monitoring and mitigation system that's ideal for the continuous regulation of oxygen below the limit of 23.6 percent in combined-use vacuum systems. The heart of the monitoring & mitigation system is a PLC that interfaces to an oxygen transmitter, a vacuum transducer, and a control valve. The unit monitors oxygen concentration and vacuum pressure and takes appropriate action based on these input parameters. The PLC will operate a valve plumbed to a regulated gas source (e.g., carbon dioxide or nitrogen) or ambient air to maintain levels below the critical threshold of 23.6%. Maintaining system vacuum pressure is always prioritized over oxygen levels; as long as vacuum pressure remains acceptable, increasing oxygen levels to the vacuum pump inlet will be mitigated.

## Model Features

The **TOM-2** (model number TOM-2095M) performs both oxygen monitoring and mitigation and is recommended for use in both in-patient and out-patient facilities where oxygen concentrations may exceed the NFPA 99 threshold of 23.6%. The TOM-2 continuously monitors and logs total oxygen concentration in order to provide periodic reports for compliance purposes.

The TOM-2 features a zirconium oxide O<sub>2</sub> transmitter with a life span of 10 years of continuous operation. Transmitter behavior is very stable under nominally changing environmental conditions of temperature, pressure, and humidity. Because of its stability, the transmitter requires only periodic testing to verify the transmitter remains calibrated for accuracy.

The system also features an alarm output relay that is triggered if the oxygen level exceeds the limit of 23.6 percent. This alarm output can be wired to the master alarm panel if a facility requires this.

# TOM-2 Operators Manual

## System Specifications

<b>Model/Part Number</b>		<b>TOM-2095M / 01-210-1</b>
<b>Description</b>		Oxygen monitoring and mitigation, vacuum pressure monitoring, alarm relay output, data logging
<b>Performance</b>	<b>Response Time</b>	Within 1 second of any change in oxygen levels
	<b>Accuracy</b>	± 0.5% of FS
	<b>Repeatability</b>	± 1% of reading
	<b>Operating Temp</b>	-40° to 122°F (-40° to +50°C)
	<b>Humidity</b>	0 – 98% RH, non-condensing
	<b>Data Logging</b>	Oxygen concentration and Vacuum Pressure readings logged every 10 seconds
	<b>Alarm Output</b>	2-wire dry contact, normally open relay commanded closed during normal operation (opens on alarm of 23.6% O <sub>2</sub> or loss of power)
<b>Oxygen Monitoring</b>	<b>Range</b>	0 – 95% oxygen concentration
	<b>Transmitter Gas Interface</b>	1/2" NPT male threaded connection
	<b>Transmitter Electrical Interface</b>	M8 4-pole connector with keyway (5m connectorized cable included with unit)
<b>Vacuum Pressure Monitoring</b>	<b>Range</b>	0 – 30 in Hg, vacuum range
	<b>Transmitter Gas Interface</b>	1/4" NPT male threaded connection
	<b>Transmitter Electrical Interface</b>	M12 4-pole connector with keyway (5m connectorized cable included with unit)
<b>Gas Mitigation</b>	<b>Gas Type</b>	Carbon dioxide, nitrogen or ambient air (with included muffler)
	<b>Gas Pressure</b>	5 – 10 psig (operating pressure range at valve inlet port)
	<b>Gas Interface</b>	1/2" NPT female threaded connection
	<b>Valve Power</b>	24VDC power is supplied by control unit (5m 3-wire cable included with unit)
<b>Electrical</b>	<b>Voltage Source</b>	110-120 VAC, 60 Hz
	<b>Power (max)</b>	18 Watts including solenoid valve and transducers
<b>Physical (Control Unit)</b>	<b>Dimensions</b>	8" (W) x 12" (H) x 6" (D)
	<b>Weight</b>	10.0 pounds (4.5 kg) including solenoid valve, transducers, and wiring
	<b>Enclosure Type</b>	NEMA 1,2,4,4X rated, polycarbonate, indoor/outdoor use

# TOM-2 Operators Manual

## System Equipment

When a TOM-2095M is purchased from EMS Healthcare LLC, the following materials are included in the delivered package to support system installation.

Part Number	Part Description	Qty
01-210-1	Programmed PLC with dry contact alarm relay, 24VDC power supply, 1A circuit breaker, terminal blocks with internal wiring, O <sub>2</sub> transmitter cable with female M8 screw-on connector, vacuum pressure transmitter cable with female M12 screw-on connector, and solenoid valve 3-wire cable with unterminated leads (all cables are 5m length) assembled within a polycarbonate wall mount enclosure.	1
01-211-1	Oxygen concentration transmitter with male M8 connector	1
01-212-1	Vacuum pressure transmitter with male M12 connector	1
01-213-1	24VDC solenoid valve with ½” NPT female connections and unterminated wire leads	1
01-222-1	Filter/muffler with ½” NPT male connection for valve inlet	1
01-223-1	½” straight to NPT brass adapter for O <sub>2</sub> transmitter	1

In addition to this material list, the installer will need to provide all the necessary tools along with materials specific to the facility where the installation will occur to complete the installation. These additional materials are detailed in the System Installation section of this manual.

## System Installation

### TOM-2 Unit Installation

**TOM-2 installation must be performed by a qualified technician trained by EMS Healthcare LLC.**

The TOM-2 enclosure should be mounted vertically on or near the vacuum pump skid to allow installation of the transmitters and valve into the facility vacuum system as indicated in the diagram below. The enclosure is supplied with 4 metal standoff brackets and screws that attach these to the rear of the enclosure. The installer must provide any additional hardware (e.g. Unistrut, super strut or angle iron, mounting hardware, washers, etc.) needed to mount the enclosure to the vacuum pump skid. See Specifications for enclosure dimensions.



ACTUAL INSTALLATION PHOTO

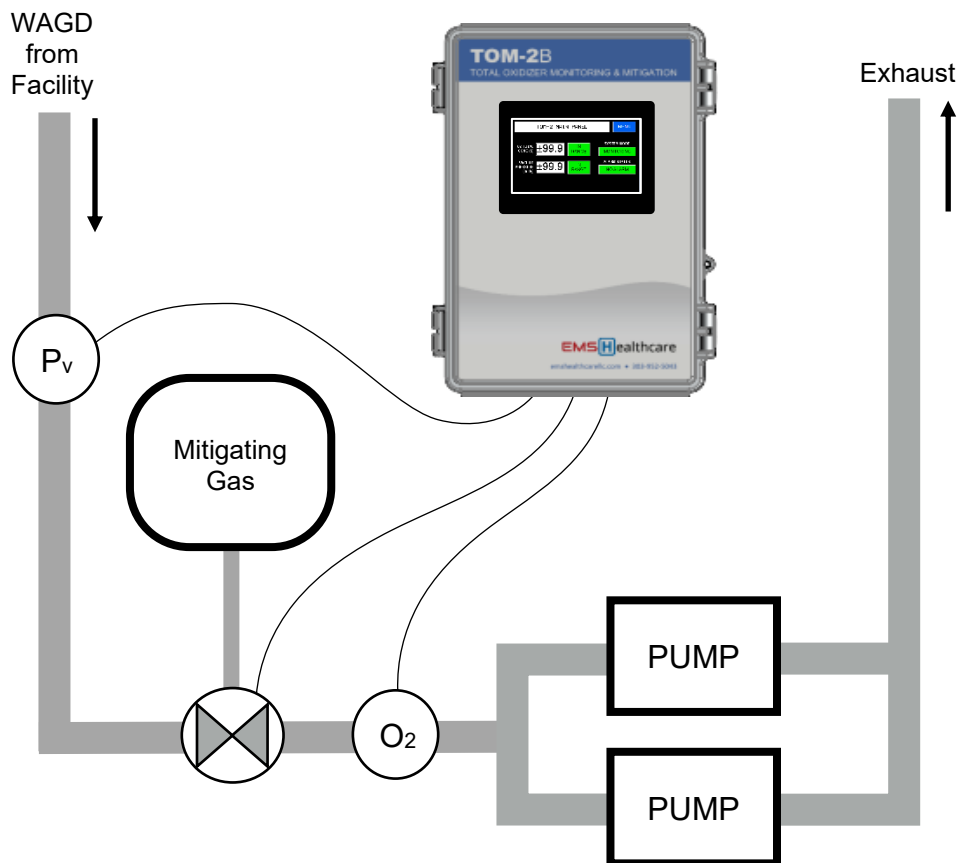

# TOM-2 Operators Manual

## TOM-2 Transmitter and Valve Installation

The TOM-2 unit comes pre-wired with connectorized 5-meter cables for the O2 transmitter and vacuum pressure transmitter and a 3-wire 5-meter cable with unterminated leads for the solenoid valve.

**NOTE:** The installer will need to provide pipe fitting T's, adapters, and/or reducers appropriate to the facility pipe configuration to complete installation of the transmitters and valve. Use Teflon tape or equivalent at all piping connections. Secure all wiring using zip-ties and coil/secure any excess wiring near the unit. Please contact EMS Healthcare at 303-952-5043 for guidance or questions.

**CAUTION: ensure electrical power to the TOM-2 is OFF before electrical connections are mated/demated at the transmitters and valve.**

1. **O2 Transmitter** – The TOM-2 is supplied with an O2 transmitter that has 1/2” straight-thread gas interface and M8 4-pole electrical connector interface. A brass adapter is also supplied to adapt the straight-thread to 1/2” NPT. Install the O2 transmitter in the common inlet piping closest to the vacuum pump inlets so that it can sense gases going into all pumps, including the gas from the mitigation valve. Once the O2 transmitter is installed in the piping system, route the pre-wired O2 transmitter cable with the M8 connector from the TOM-2 unit over to the O2 transmitter and mate the connector to the transmitter.



2. **Mitigation Solenoid Valve** – The TOM-2 is supplied with a normally closed solenoid valve with 1/2” NPT gas interfaces for controlling mitigating gas. A brass filter is also supplied and should be mated to the inlet side of the valve if room air is to be used for mitigating gas. Install the valve in the system upstream of where the O2 transmitter is located so that the O2 transmitter can measure the effects of mitigating gas when the valve is opened. Adequate gas mixing must be assured before vacuum system gases pass by the O2 transmitter. Once the valve is installed in the piping system, route the 3-wire (RED, BLACK, WHITE) unterminated solenoid wires to the valve location. A type-LB conduit body and wire nuts will be needed for completing wiring terminations at the solenoid valve electrical interface. The solenoid valve operates with 24VDC so the RED (V+) and BLACK (V-) wires from the TOM-2 unit should be connected to the RED wires at the solenoid. The WHITE wire from the TOM-2 is a grounding wire and should be connected to the GREEN wire at the solenoid interface.



3. **Vacuum Pressure Transmitter** – The TOM-2 is supplied with a Vacuum Pressure transmitter that has 1/4” NPT gas interface and M12 4-pole electrical connector interface. Install the vacuum transmitter near the vacuum port used to sense vacuum levels at the pump control panel. Once the transmitter is installed in the piping system, route the pre-wired vacuum transmitter cable with the M12 connector from the TOM-2 unit over to the transmitter location and mate the connector to the transmitter.



# TOM-2 Operators Manual

## Facility Interface Wiring

**Electrical installation must be performed by a qualified electrician.**

1. **Power Input** - The TOM-2 requires 120VAC electrical power (2-conductor plus ground). The power input connections are to be made at terminal blocks inside the unit enclosure. The installer must provide all wiring to interface this power input with an appropriate power source (typically connected to 1A source in the vacuum pump control panel).

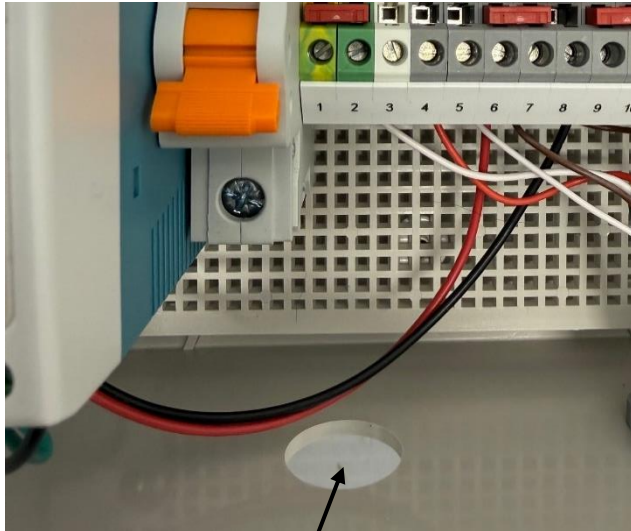

Insert 120VAC armored cable (or equivalent) wiring thru left wiring port



Hot/Black Wire to Circuit Breaker input

Neutral/White Wire to White Terminal #3

Ground/Green Wire to Green/Yellow Ground Terminal #1

2. **O2 Alarm Relay Output** – The TOM-2 includes an O2 Alarm relay output (2-wire dry contact, normally open) that can be wired to the facility master alarm panel. This relay output is commanded closed for normal operation and will open when an O2 Alarm is indicated (23.6% O2 is exceeded) or when a loss of 120VAC power to the unit occurs. See below for where these connections can be found within the TOM-2 enclosure. The installer must provide all wiring to interface this alarm output with the facility’s master alarm panel.

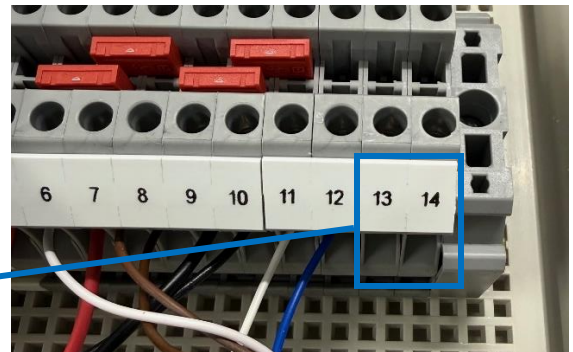

Terminal connectors #13 and #14 are the **O2 Alarm** relay output terminals

# TOM-2 Operators Manual

## Mitigating Gas

The mitigation of high oxygen levels can be implemented with ambient air, carbon dioxide gas, or nitrogen gas.

For in-patient facilities, the combined WAGD systems typically have large system volumes such that, when oxygen is introduced into the system, its contribution to the overall percentage of gases is small and easily mitigated by dilution in the total system volume or by introduction of a small amount of mitigating gas. Therefore, ambient air is suggested as the initial mitigating gas for these in-patient facilities. The TOM-2 comes equipped with an air inlet filter/muffler on the solenoid valve for installations where ambient air will be used. After installation, if the system shows recurring O<sub>2</sub> alarms with ambient air mitigation, carbon dioxide or nitrogen may be required as a mitigating gas.

For out-patient facilities and surgery centers, the rise rate and peak level of oxygen concentration in the system during facility use can be much higher than what is seen in an in-patient facility due to smaller system volumes. Therefore, it is suggested that these facilities use carbon dioxide or nitrogen as a mitigating gas to more rapidly respond to increasing oxygen levels detected by the TOM-2. See the Specifications page for gas connection sizing and acceptable pressure input levels if carbon dioxide or nitrogen gas will be used.

The mitigating gas valve should be installed at a point where all vacuum system input is consolidated to one line upstream of the vacuum pumps. Larger valve sizes (3/4" and 1") are available if the vacuum pump system requires higher flow.

## Initial Power Application

On initial application of 120VAC power following system installation, the system will power up with initial settings entered from the factory. The touch screen on the front cover of the unit will power on and show the TOM-2 MAIN PANEL. Verify that the following steps occur automatically:

1. Initial System Mode indicates "WARMING UP" and then transitions to "MONITORING" after about 2 minutes.
2. Once System Mode indicates "MONITORING", O<sub>2</sub>% and Vacuum Pressure readings are displayed.

Once the unit is operational, the installer should baseline the O<sub>2</sub> transmitter concentration for the facility location and altitude. This is done by exposing the transmitter to ambient air for at least 2 minutes and recording the concentration reading. This baseline reading can then be used to ensure the O<sub>2</sub> transmitter is not drifting during annual maintenance checks. Refer to "Periodic Transmitter Calibration" under the **System Maintenance** section in this manual for the calibration process.

## TOM-2 MAIN Screen

# TOM-2 Operators Manual

## INPUTS

O2 TOT CONC = absolute oxygen concentration (1 – 95%)  
VAC PRESS = vacuum pressure (0 – 29 in Hg)

## O2 STATUS

IN RANGE (green) = O2 is in expected range  
TOO HIGH (yellow) = O2 is at elevated levels, mitigation is activated

## SYSTEM MODE

WARMING UP (blinking yellow) = system is warming up (approx. 2 minutes)  
MONITORING (green) = system is monitoring nominal O2 levels  
MITIGATING (blinking green) = system is mitigating elevated O2 levels  
MONITOR ONLY (yellow) = system is in "monitor only" mode – no mitigation

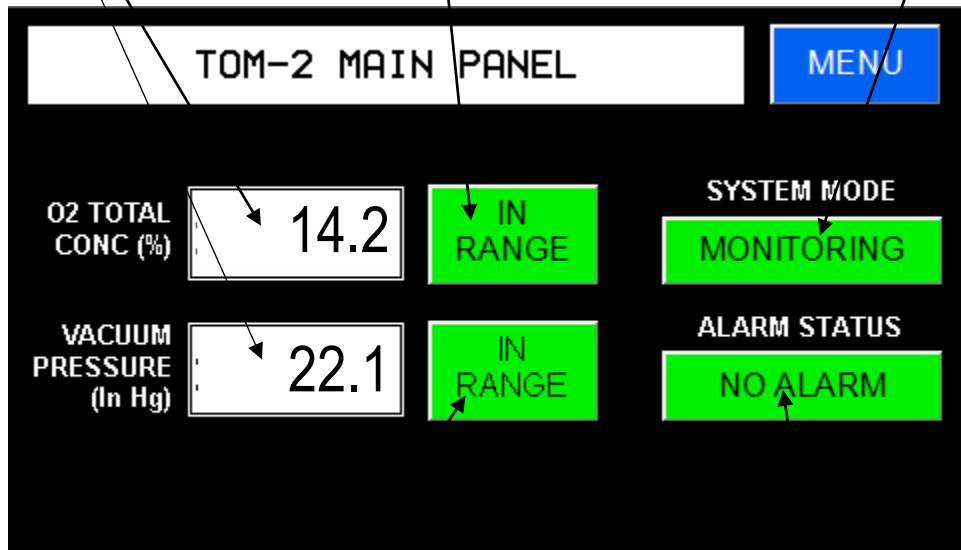

## VACUUM STATUS

IN RANGE (green) = vacuum pressure is in range for mitigation  
TOO LOW (yellow) = vacuum pressure is too low for mitigation

## ALARM STATUS

NO ALARM (green) = O2 levels are being maintained below alarm limit  
ALARM (red) = O2 level has exceeded alarm limit

# TOM-2 Operators Manual

## System Operation

The TOM-2 continuously monitors O2% levels against pre-programmed limits.

1. O2% - This measurement shows instantaneous O2 concentration values and is used by the PLC to determine when mitigation is required. This measurement is shown on the MAIN screen and on the TREND CHART screen. Min/max values can be found on the STATS screen.
2. O2% Filtered – This measurement is generated by averaging O2% values over a period of time and is used to determine when to trigger the O2 alarm. This measurement is shown on the TREND CHART screen and min/max values can be found on the STATS screen.

If the system is in Mitigate Mode, the system will trigger O2 mitigation when O2 levels exceed a pre-programmed setpoint that is above nominal O2 levels and below the O2 alarm limit. Mitigation will remain active as long as elevated O2 levels persist and vacuum pressure is not adversely affected. Once O2 levels drop back to nominal levels, mitigation will stop and system will continue to monitor O2 levels for additional excursions.

If the system detects an O2% above the O2 alarm limit of 23.6% for a sustained period of time (O2% Filtered), the system will open the O2 Alarm relay, sending an indication to the Master alarm panel if this relay output is wired to the facility panel. If this situation occurs, the facility should develop a procedure to physically monitor the vacuum system pumps, inspect the O2% reading on the TOM-2 and, if the reading is below the O2 alarm limit of 23.6%, reset the O2 alarm. Then contact the TOM-2 installation agency for further evaluation of the system to understand the cause and determine whether TOM-2 setting adjustments are required.

## System Configuration

The TOM-2 provides a touch screen interface that allows the user to monitor system operations and adjust configuration settings. The MAIN screen allows access to Settings, Calibrations, real-time data trending, and system statistics and faults by pressing MENU on the display. The MENU screen (shown below) also displays the date/time and the software version loaded into the PLC.

**MENU Screen**

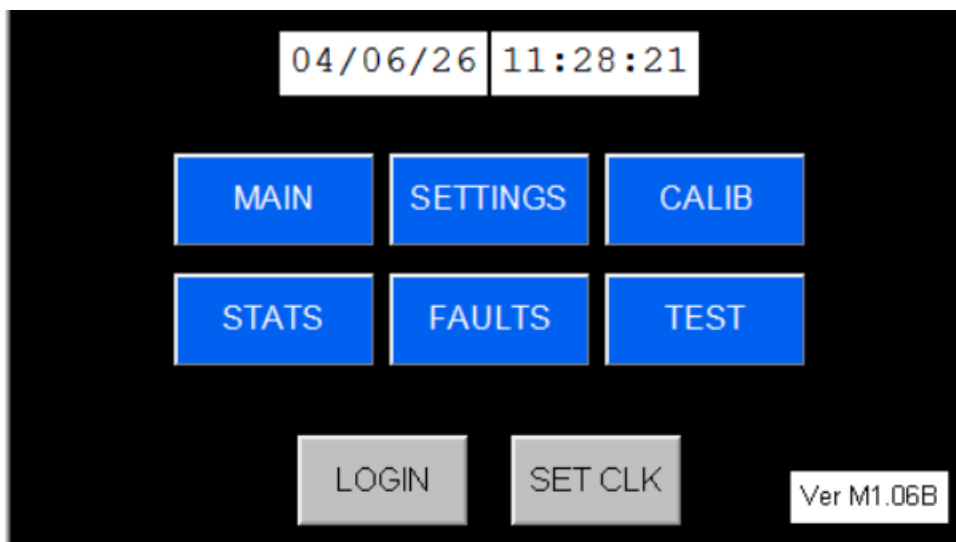

## TOM-2 Operators Manual

### Settings

**Access to this screen is password protected to prevent unauthorized personnel from changing system settings after initial system installation.**

The SETTINGS screen (below) enables the operator to modify settings for the mitigation solenoid valve operation setpoints and vacuum override as well as change the TOM-2 mode (monitor only or mitigate) and reset system statistics.

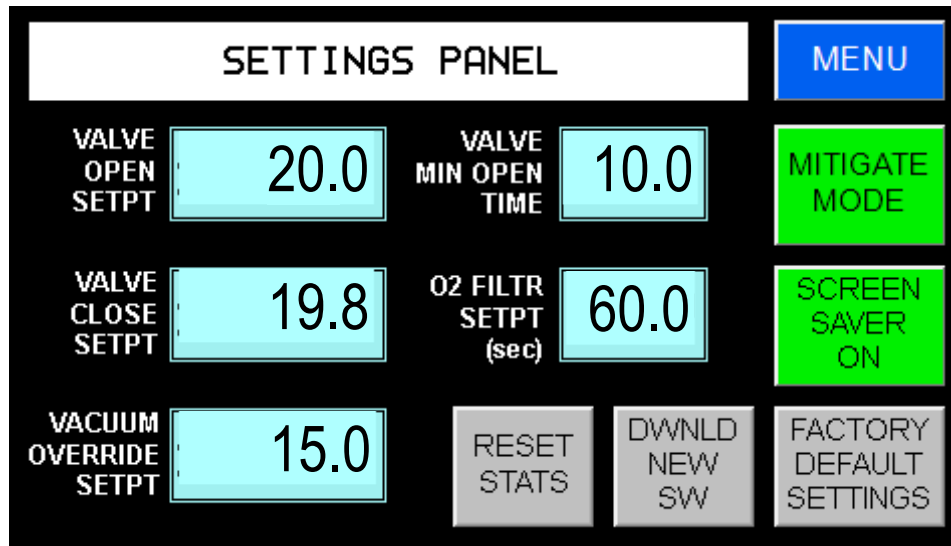

3. Setpoints – This section describes the recommended settings based on the type of facility the unit is installed in. All settings will remain active even after a power reset.
  - a. O2 Mitigation settings (Mitigation mode only)
    - i. The operator can adjust mitigation valve Open Setpoint, Close Setpoint, and Min Open Time settings based on facility vacuum system design. These settings should be adjusted to provide sufficient time for the mitigation process to affect the oxygen levels and avoid an O2 alarm situation. The factory default settings have been evaluated under test and should be acceptable for use in most facilities.
    - ii. Initial Valve Open Setpoint is 20.0% O2 concentration and can be adjusted by operator. This setting can be modified by touching the value window (a pop-up window will appear to adjust the value; once a new value is input, press ENTER).
    - iii. Initial Valve Close Setpoint is 19.8% O2 concentration and can be adjusted by the operator. This setting can be modified by touching the value window (a pop-up window will appear to adjust the value; once a new value is input, press ENTER).

## TOM-2 Operators Manual

- iv. Initial Valve Min Open Time is set at 10 seconds. This setting can be modified by touching the value window (a pop-up window will appear to adjust the value; once a new value is input, press ENTER).
  - v. Mitigation operation - when the Valve Open Setpoint is exceeded (O2% value is higher than setpoint), System Mode on the MAIN screen will indicate MITIGATING in blinking green; otherwise, it displays MONITORING in solid green.
    - 1. Solenoid valve output is activated for a time period specified by the Valve Min Open Time setting.
    - 2. Once the Valve Min Open Time expires and the O2% is confirmed to be below the Valve Close Setpoint, the valve is closed.
    - 3. If O2% level remains above the Valve Open Setpoint after the Valve Min Open Time expires, the valve will remain open until the O2% level drops below the Valve Close Setpoint.
    - 4. If vacuum pressure level falls below the minimum vacuum level setting when O2 mitigation is active, the solenoid valve output will be immediately deactivated and remain deactivated until vacuum level rises above the minimum limit (plus 0.5 in Hg for valve on/off hysteresis).
- b. Vacuum Override setting (Mitigation mode only)
- i. Vacuum Override is used internally by the O2 mitigation algorithm in order to prioritize vacuum system pressure over O2 mitigation. If the vacuum system pressure falls below this minimum pressure limit, all O2 mitigation activity will be disabled until vacuum pressure returns to a value above the minimum limit. There is no alarm output from the device for this indication because the vacuum system controller already has such an alarm.
  - ii. Initial value for Vacuum Override is 15.0 in Hg and can be adjusted by the operator. This setting can be modified by touching the value window (a pop-up window will appear to adjust the value; once a new value is input, press ENTER).
  - iii. When the Vacuum Override setting is exceeded (pressure falls BELOW the limit), System Mode on the MAIN screen will display MONITORING; otherwise, it displays MITIGATING in blinking green when mitigation is active and vacuum pressure is within limits.
- c. O2 Filter setting
- i. The O2 Filter Setpoint is used internally by the O2 alarm algorithm to perform a running average of the instantaneous O2% values from the transmitter in order to avoid triggering the alarm for momentary excursions above the alarm limit. The setpoint defines the time duration for the running average.
  - ii. Initial value of the O2 Filter setpoint is 60 seconds and can be adjusted by the operator. This setting can be modified between 1 and 120 seconds by touching the value window (a pop-up window will appear to adjust the value;

## TOM-2 Operators Manual

once a new value is input, press ENTER).

4. Monitor/Mitigate Mode - The system operates in monitor only or mitigation modes. The Settings screen shows Monitor Only Mode or Mitigate Mode depending on the setting.
  - a. Press MONITOR ONLY MODE to change setting to MITIGATE MODE; likewise, press Mitigate Mode to change back to Monitor Only Mode. The selected setting will remain active even after a power reset.
  - b. In MONITOR ONLY MODE, the system continuously monitors oxygen levels and provides O2 alarm indications. In this mode, only the O2 transmitter input is required.
  - c. In MITIGATE MODE, the system monitors oxygen and vacuum pressure levels and mitigates elevated O2 levels by opening a mitigating gas valve. In this mode, the O2 transmitter input, vacuum pressure input, and solenoid valve output are required. Once selected, MITIGATE MODE will remain selected even after a power reset.
5. Screen Saver On - The touchscreen display will go blank after 10 minutes of no operator use in its default setting. The Settings screen shows Screen Saver On or Screen Saver Off depending on the setting.
  - a. Press SCREEN SAVER ON to change setting to SCREEN SAVER OFF; likewise, press SCREEN SAVER OFF to change back to SCREEN SAVER ON.
  - b. When in SCREEN SAVER OFF, the touchscreen display will remain on indefinitely.
  - c. The selected setting will default back to SCREEN SAVER ON after a power reset.
6. Reset Statistics – The system generates statistical operating data which is displayed on the STATS screen. Press the RESET STATS button to clear all existing statistics from memory and begin generating new data.
  - a. This button should only be pressed when the operator knows existing statistics contain data generated during events NOT representative of normal facility operations, like initial system installation and checkout, or power interruption, or transmitter calibration.
  - b. Once this button is pressed, a **warning screen** will appear to ensure the operator did not mistakenly press the button. If operator still wants to proceed, press OK on the warning screen to proceed.
7. Download New Software – this button is reserved for future use. Please do not use.
8. Factory Default Settings – Press the FACTORY DEFAULT SETTINGS button to return all setpoints back to the default values used during factory checkout.
  - a. This button should only be pressed by the operator if setpoints have been adjusted and the unit performance is not as expected.
  - b. Once this button is pressed, a **warning screen** will appear to ensure the operator did not mistakenly press the button. If operator still wants to proceed, press OK on the warning screen to proceed.

## TOM-2 Operators Manual

### Transmitter Calibration

**Access to this screen is password protected to prevent unauthorized personnel from changing system settings after initial system installation.**

The CALIBRATION screen (below) enables the operator to add/modify value offsets for the O2 transmitter and the Vacuum pressure transmitter.

The screenshot shows a black background with white text and input fields. At the top, there is a white header bar with the text "CALIBRATION PANEL" and a blue button labeled "MENU". Below the header, there are four input fields arranged in a 2x2 grid. The top-left field is labeled "O2 TOTAL CONC (%)" and contains the value "14.2". The top-right field is labeled "O2 CONC OFFSET" and contains the value "2.1". The bottom-left field is labeled "VACUUM PRESSURE (In Hg)" and contains the value "22.3". The bottom-right field is labeled "VACUUM PRESSURE OFFSET" and contains the value "0.5".

Parameter	Value
O2 TOTAL CONC (%)	14.2
O2 CONC OFFSET	2.1
VACUUM PRESSURE (In Hg)	22.3
VACUUM PRESSURE OFFSET	0.5

#### 1. O2 Transmitter Offset Input

This field allows for O2 transmitter reading adjustment as part of regular TOM-2 system maintenance. Adjustment should only be performed by qualified personnel trained by EMS Healthcare LLC.

- a. O2 transmitter OFFSET can be adjusted up/down from the factory default setting of 0.0

#### 2. Vacuum Pressure Transmitter Offset Input

This field allows for vacuum pressure transmitter adjustment as part of regular TOM-2 system maintenance. Adjustment should only be performed by qualified personnel trained by EMS Healthcare LLC.

- a. Vacuum pressure transmitter OFFSET can be adjusted up/down from the factory default setting of 0.0

# TOM-2 Operators Manual

## Test Mode

**Access to this screen is password protected to prevent unauthorized personnel from changing system settings after initial system installation.**

The TEST screen (below) enables the operator to manually test each output signal of the TOM-2: the Mitigating Valve output and the Alarm output.

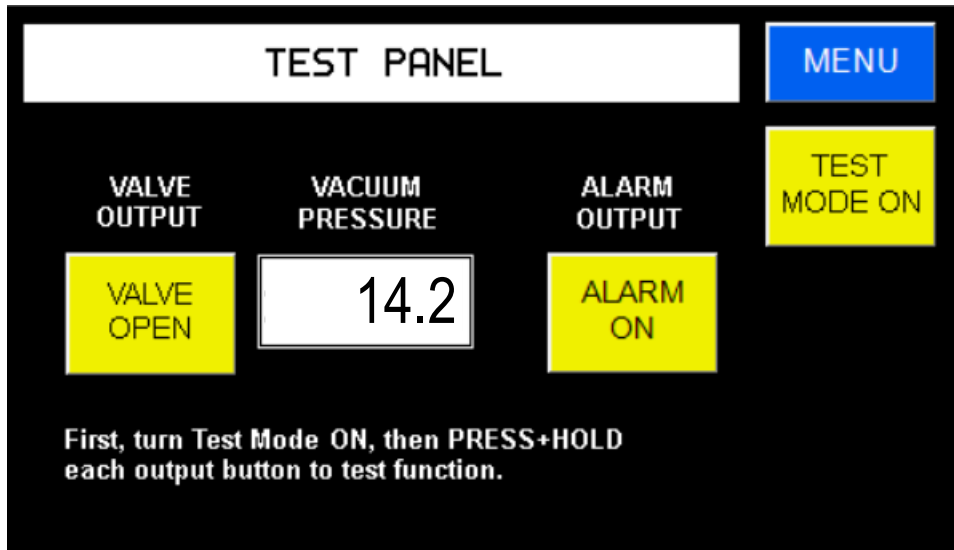

### 1. Test Mode On

This button must be pressed first to turn ON Test Mode in the unit.

**CAUTION: turning ON Test Mode will disable normal operations of the TOM-2 unit. O2 concentrations will not be mitigated and vacuum pressure will not be protected.**

### 2. Valve Output

- a. With Test Mode ON, pressing the Valve Output button will activate (open) the mitigating valve for as long as the button is held pressed. Once the button is released, the Valve Output will deactivate (close).
- b. Vacuum pressure transmitter readings are shown in case the mitigating valve is already plumbed into the vacuum system so the impact of opening the valve can be seen by the operator.

### 3. Alarm Output

- a. With Test Mode ON, pressing the Alarm Output button will activate (open) the alarm relay for as long as the button is held pressed. Once the button is released, the Alarm Output will deactivate (close the relay).

# TOM-2 Operators Manual

## Statistics

The STATISTICS screen (below) enables the operator to review system statistics that are generated during nominal facility operations.

STATISTICS PANEL		MENU		
	MIN	MAX		
O2 TOTAL CONC (%)	3.5	21.2	O2 RATE MAX (%/sec)	16.1
O2 TOTAL CONC FILT (%)	6.2	20.6	MITIGATION CYCLE CNT	15
VACUUM PRESSURE (In Hg)	15.3	26.5		

1. O2% Minimum and Maximum readings – these values represent the lowest and highest system readings for O2% values since the system was started or the STATS RESET button was last pressed.
2. O2% Filtered Minimum and Maximum readings – these values represent the lowest and highest system readings for O2% filtered values since the system was started or the STATS RESET button was last pressed.
3. Vacuum Pressure Minimum and Maximum readings – these values represent the lowest and highest readings for Vacuum Pressure values since the system was started or the STATS RESET button was last pressed.
4. O2% Rate Maximum – this value represents the highest increasing rate of O2% that the system detected. This value is currently not used by the mitigation algorithm and is only collected for facility diagnostics.
5. Mitigation Cycle Count – this value represents the total number of mitigation cycles the TOM-2 has performed during the time it has been operational.

## TOM-2 Operators Manual

### Faults

The Faults screen (below) enables the operator to evaluate system faults and alarms that are generated during facility operations.



#### 1. O2 Alarm Triggered

- a. The O2 alarm limit is set at 23.6% as dictated by NFPA 99 and cannot be adjusted by the operator.
- b. When the alarm limit is exceeded with persistence (value is higher than limit for a sustained period of time), ALARM in red is set on the MAIN screen and O2 ALARM TRIGGERED will change from green to red on the FAULTS screen.
- c. When O2 ALRM TRIGGERED is indicated, the O2 Alarm relay output will remain latched ON (relay is open) until the operator resets it.

#### 2. Reset O2 Alarm

- a. To reset the O2 Alarm, first ensure O2% is reading below 23.6%. If O2% is reading nominally, then press RESET O2 ALARM. Then press MENU and select MAIN to return to the main screen and verify that the ALARM STATUS indicator now shows NO ALARM in green.

# TOM-2 Operators Manual

## Logging In

The LOGIN button is used to access the SETTINGS and CALIB screens. A User ID and Password are required to log in. Press the LOGIN button to bring up the log in screen. Enter the User ID and press the ENT button, then enter the Password and press the ENT button. Once both items are entered, press the SUBMIT button to log in. If no errors were detected, the SETTINGS and CALIB screens can now be accessed by the operator. After 10 minutes of inactivity on the PLC, the password-protected screens will require the operator to log in again.

## Adjusting Date and Time

If the date and time are not correct on the MENU screen, then press the SET CLK button which will take you to the screen below. Press the “+” or “-” buttons to adjust the appropriate item and then press MENU to return to the MENU screen.

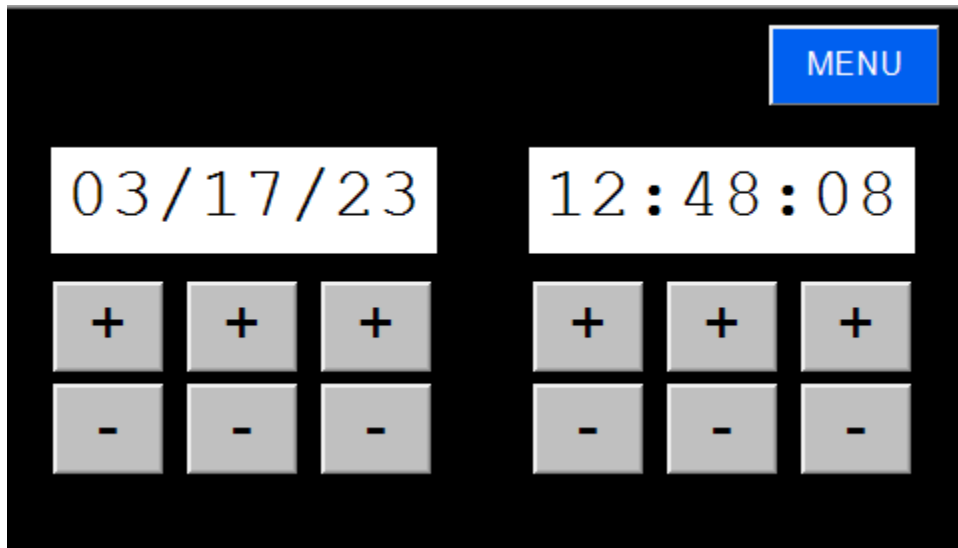

## Data Logging

The TOM-2 system utilizes a real-time logging function that writes data directly to an attached flash drive (provided with the unit) containing sufficient memory to record more than one year’s worth of data. O2 level, Vacuum Pressure level, and O2 Filtered data are logged every ten (10) seconds to provide a time history of the TOM-2 operation for review.

The data stored in the flash drive can be reviewed by removing the drive from the unit, inserting the drive into the USB port of a laptop computer, and importing the data as a CSV file into a spreadsheet application. Some manipulation of the data may be required.

## TOM-2 Operators Manual



### System Maintenance

#### Annual Compliance Reporting

EMS Healthcare recommends downloading the time history log from the thumb drive on an annual basis to provide the facility a report of oxygen concentration compliance to the NFPA 99 requirement.

#### Periodic Transmitter Check

EMS Healthcare recommends checking the O<sub>2</sub> transmitter on an annual basis to verify transmitter accuracy. This check can be conducted during the same visit when the time history log is downloaded from the unit.

To check the O<sub>2</sub> transmitter, remove the transmitter from the vacuum system by unscrewing the transmitter from its port.

**CAUTION: do NOT unplug the transmitter cable unless power to the unit has been shut off first**

Leave the transmitter in ambient air for at least 2 minutes and then verify the O<sub>2</sub>% is reading the same as the baseline reading taken at initial system startup (refer to Initial Power Application under System Installation). If the transmitter is not at this value, adjust the O<sub>2</sub> transmitter offset value (refer to O<sub>2</sub> Transmitter Calibration under System Operation) to re-calibrate it.

Once the O<sub>2</sub> transmitter has been verified, it should be re-installed into the transmitter port.

### O2 Concentration at Vacuum Pressure

The O2 transmitter is designed to measure O2 concentrations relative to sea-level ambient pressure of 14.7 psia. When exposed to lower pressures due to vacuum conditions, the transmitter will count fewer O2 molecules and produce an O2 concentration relative to sea-level pressure. While the fractional oxygen content in the local ambient gas remains relatively constant (e.g., 20.9% relative to other gases in the local ambient air), the O2 concentration being reported by the transmitter will decrease at ambient pressures lower than sea-level and increase at ambient pressures higher than sea-level as it measures absolute oxygen molecule content relative to sea-level.

# TOM-2 Operators Manual

## Schematic Diagram

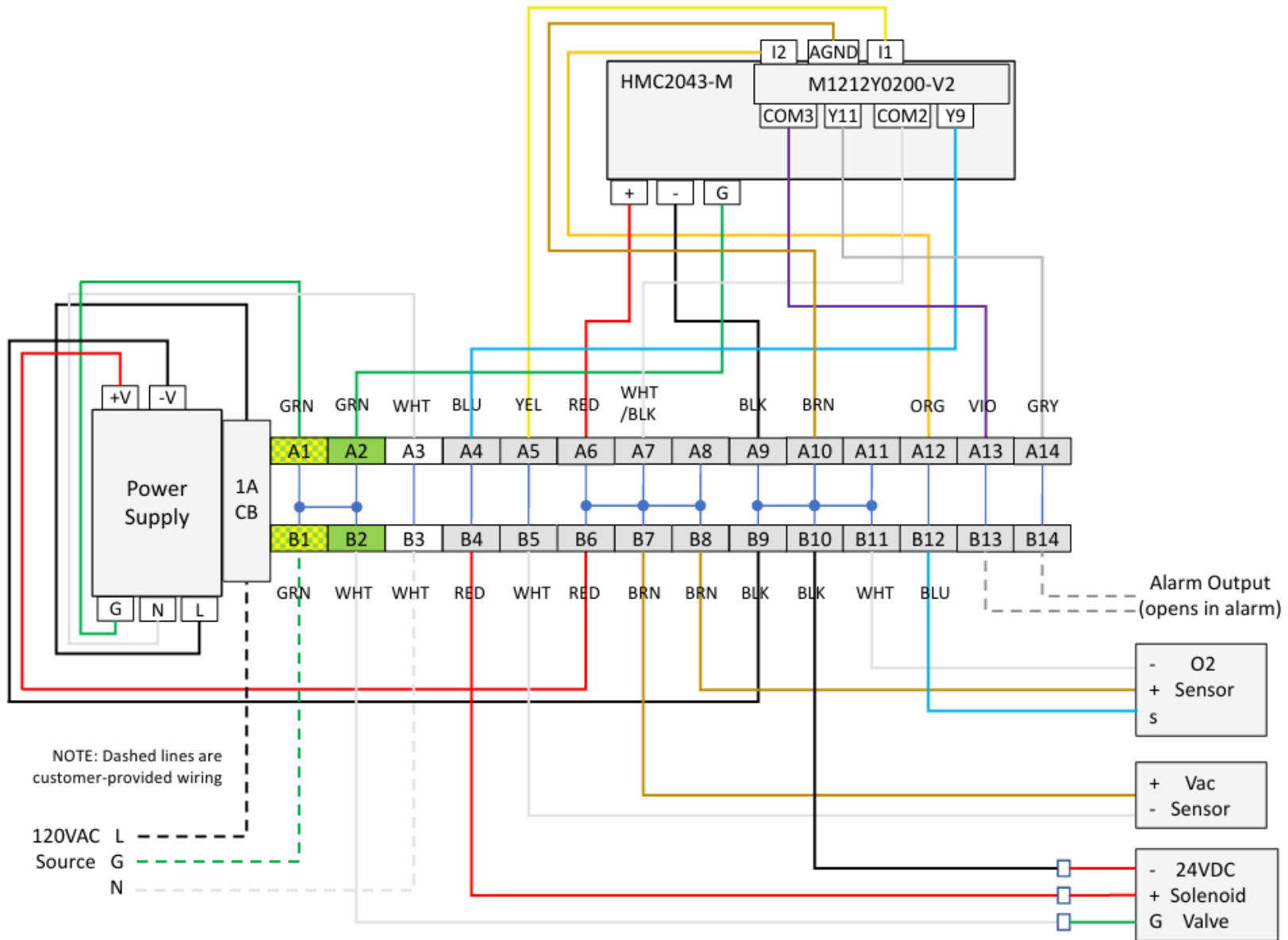

# TOM-2 Operators Manual

## Limited Warranty

General. EMS Healthcare warrants each of our products to be free from defects in material and workmanship (“defects”) at the date of shipment. This warranty shall apply only to products that are purchased and used in the United States of America. EXCEPT AS SET FORTH BELOW, NO OTHER WARRANTY, WHETHER EXPRESS OR IMPLIED, INCLUDING ANY WARRANTY OF MERCHANTABILITY OR FITNESS FOR A PARTICULAR PURPOSE, SHALL EXIST IN CONNECTION WITH THE SALE OR USE OF SUCH PRODUCTS. TO THE EXTENT PERMITTED BY LAW, ANY AND ALL IMPLIED WARRANTIES ARE EXCLUDED. All warranty claims must be made in writing and delivered to EMS Healthcare at the company address listed on our website ([www.emshealthcarellc.com](http://www.emshealthcarellc.com)), or such claim shall be barred. Upon timely receipt of a warranty claim, EMS Healthcare shall inspect the product claimed to have a defect, and EMS Healthcare shall repair, or, at its option, replace, free of charge, any product which it determines to have a defect; provided, however, that if circumstances are such as to preclude the remedying of defect by repair or replacement, EMS Healthcare shall, upon return of the product, refund to the buyer any part of the purchase price of such products paid to EMS Healthcare. Freight for returning products to EMS Healthcare for inspection shall be paid by the buyer. The warranties and remedies herein are the sole and exclusive remedy for any breach of warranty or for any other claim based on any defect, or non-performance of the products, whether based upon contract, warranty or negligence.

Period of Warranty – Parts and Labor. EMS Healthcare warrants and represents all products shall be free from defects for the first eighteen (18) months from the date of shipment by EMS Healthcare, or twelve (12) months from the documented date of startup, whichever occurs first. During such warranty period, EMS Healthcare shall be fully liable for all defects within the product.

Exceptions. Notwithstanding anything to the contrary herein, EMS Healthcare shall have no warranty obligations with respect to products:

- a) that have not been installed in accordance with EMS Healthcare’s written specifications and instructions;
- b) that have not been maintained in accordance with EMS Healthcare’s written instructions;
- c) that have been materially modified without the prior written approval of EMS Healthcare;
- d) that experience failures resulting from operation, either intentional or otherwise, in excess of rated capacities or environmental conditions or in an otherwise improper manner;
- e) that have ordinary wear and tear.

Limitation of Liability. NOTWITHSTANDING ANYTHING TO THE CONTRARY HEREIN, TO THE EXTENT ALLOWABLE UNDER APPLICABLE LAW, UNDER NO CIRCUMSTANCES SHALL EMS HEALTHCARE BE LIABLE FOR ANY INCIDENTAL, CONSEQUENTIAL, PUNITIVE, SPECULATIVE OR INDIRECT LOSSES OR DAMAGES WHATSOEVER ARISING OUT OF OR IN ANY WAY RELATED TO ANY OF THE PRODUCTS OR GOODS SOLD OR AGREED TO BE SOLD BY EMS HEALTHCARE TO THE BUYER. TO THE EXTENT ALLOWABLE UNDER APPLICABLE LAW, EMS HEALTHCARE’S LIABILITY IN ALL EVENTS IS LIMITED TO, AND SHALL NOT EXCEED, THE PURCHASE PRICE PAID.